



Product description

- The crm+ sensor with one analogue output measures the distance to an object within the detection zone contactless. A signal proportional to distance is created according to the adjusted window limits of the analogue characteristic curve.
- The ultrasonic transducer surface of the crm+ sensors is laminated with a PEEK film. The transducer itself is sealed against the housing by a PTFE joint ring. This composition ensures a high resistance against many aggressive substances.
- All settings are done with two push-buttons and a three-digit LED display (TouchControl).
- Three-colour LEDs indicate all operation conditions.
- Choosing between rising and falling output characteristic is possible.

- The sensors are adjustable manually via TouchControl or via Teach-in procedure.
- Useful additional functions are set in the Add-on menu.
- Using the LinkControl adapter (optional accessory) and the LinkControl software for Windows®, all Teach-in and additional sensor parameter settings can be optionally undertaken.

The crm+ sensors have a blind zone in which distance measurement is not possible. The operating range indicates the distance of the sensor that can be applied with normal reflectors with sufficient function reserve. When using good reflectors, such as a calm water surface, the sensor can also be used up to its maximum range. Objects that strongly absorb (e.g. plastic foam) or diffusely reflect sound (e.g.

pebble stones) can also reduce the defined operating range.

Safety Notes

- Read the operating instructions prior to start-up.
- Connection, installation and adjustment works may only be carried out by expert personnel.
- No safety component in accordance with the EU Machine Directive, use in the area of personal and machine protection not permitted

Proper Use

crm+ ultrasonic sensors are used for non-contact detection of objects.

Synchronisation

If the assembly distances shown in Fig. 1 for two or more sensors are exceeded the integrated synchronisation should be used. Connect Sync/Com-channels (pin 5 at the units receptacle) of all sensors (10 maximum).

crm+25...	≥0.35 m	≥2.50 m
crm+35...	≥0.40 m	≥2.50 m
crm+130...	≥1.10 m	≥8.00 m
crm+340...	≥2.00 m	≥18.00 m
crm+600...	≥4.00 m	≥30.00 m

Fig. 1: Assembly distances, indicating synchronisation/multiplex

Multiplex mode

The Add-on-menu allows to assign an individual address »01« to »10« to each sensor connected via the Sync/Com-channel (Pin5). The sensors perform the ultrasonic measurement sequentially from low to high address. Therefore any influence between the sensors is rejected. The address »00« is reserved to synchronisation mode and deactivates the multiplex mode. To use synchronised mode all sensors must be set to address »00«.

Installation

- Assemble the sensor at the installation location.
- Plug in the connector cable to the M12 connector, see Fig. 2.

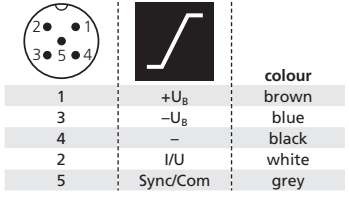

Fig. 2: Pin assignment with view onto sensor plug and colour coding of the microsonic connection cable

Start-up

- Connect the power supply.
- Set the parameters of the sensor manually via TouchControl (see Fig. 3 and Diagram 1)
- or use the Teach-in procedure to adjust the detect points (see Diagram 2).

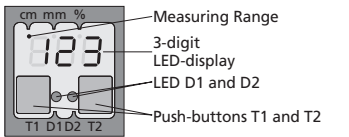

Fig. 3: TouchControl/LED display

Factory setting

- crm+ sensors are delivered factory made with the following settings:
- Rising analogue characteristic
- Window limits for the analogue output set to blind zone and operating range
- Measurement range set to maximum range

Maintenance

crm+ sensors work maintenance free. Small amounts of dirt on the surface do not influence function. Thick layers of dirt and caked-on dirt affect sensor function and therefore must be removed.

Notes

- As a result of the design the assembly of PEEK film and PTFE joint ring is not gas-proof.
- The chemical resistance has to be tested experimentally if necessary.
- crm+ sensors have internal temperature compensation. Because the sensors heat up on their own, the temperature compensation reaches its optimum working point after approx. 30 minutes of operation.
- If an object is within the set window limits of the analogue output, then LED D1 lights up green, if the object is outside the window limits, then LED D1 lights up red.
- The load put to the analogue output is detected automatically when turning supply voltage on.
- During normal mode operation, the measured distance value is displayed on the LED-indicator in mm (up to 999 mm) or cm (from 100 cm). Scale switches automatically and is indicated by a point on top of the digits. Alternatively a percentage scale may be set in the add-on menu. In this connection 0 % and 100 % correspond to the set window limits of the analogue output.
- If no objects are placed within the detection zone the LED-indicator shows »--«.
- The sensor can be set to its factory setting, see Diagram 3.
- If no push-buttons are pressed for 20 seconds during parameter setting mode the made changes are stored and the sensor returns to normal operating mode.

Show parameters

- In normal operating mode shortly push T1. The LED display shows »PAR.«
- Each time you tap push-button T1 the actual settings of the analogue output are shown.

Operating Manual

crm+ Ultrasonic Sensors with one analogue output

- crm+25/IU/TC/E
- crm+35/IU/TC/E
- crm+130/IU/TC/E
- crm+340/IU/TC/E
- crm+600/IU/TC/E

Diagram 1: Set sensor parameters numerically using LED display

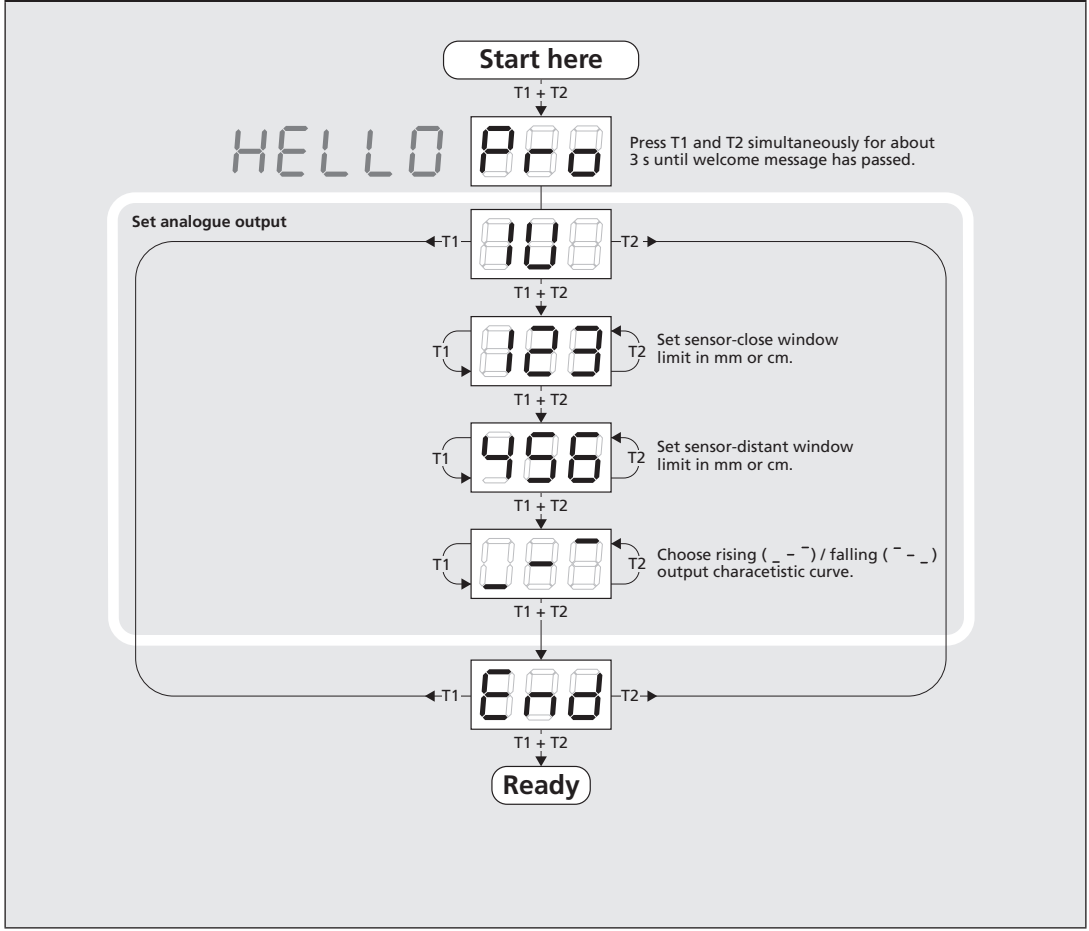

Diagram 2: Set sensor parameters via Teach-in procedure

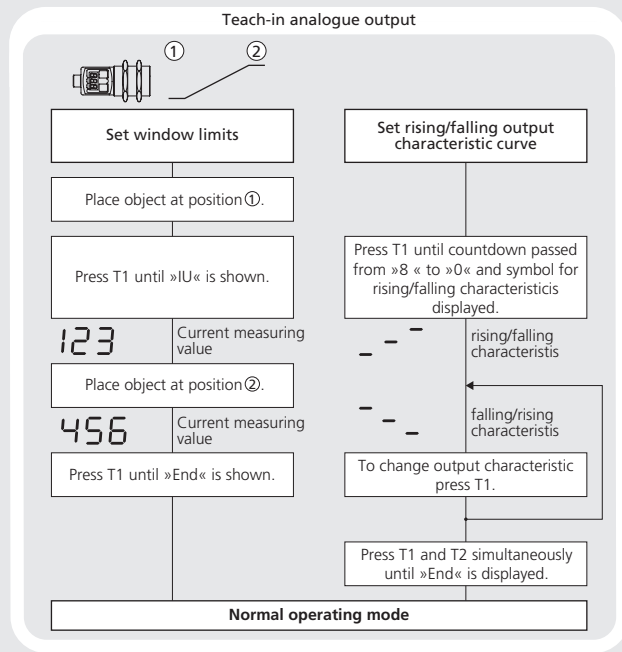

Diagram 3: Key lock and factory setting

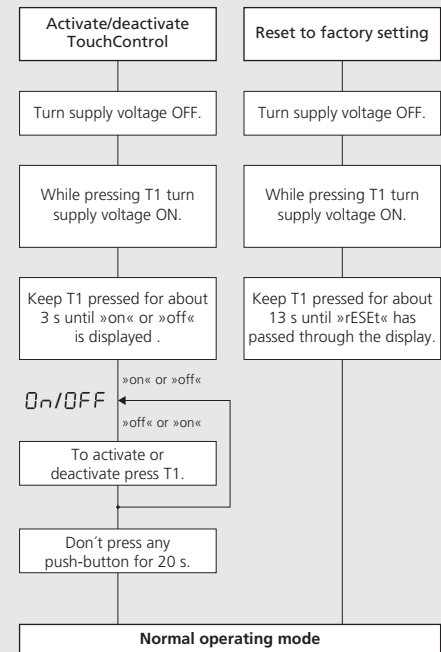
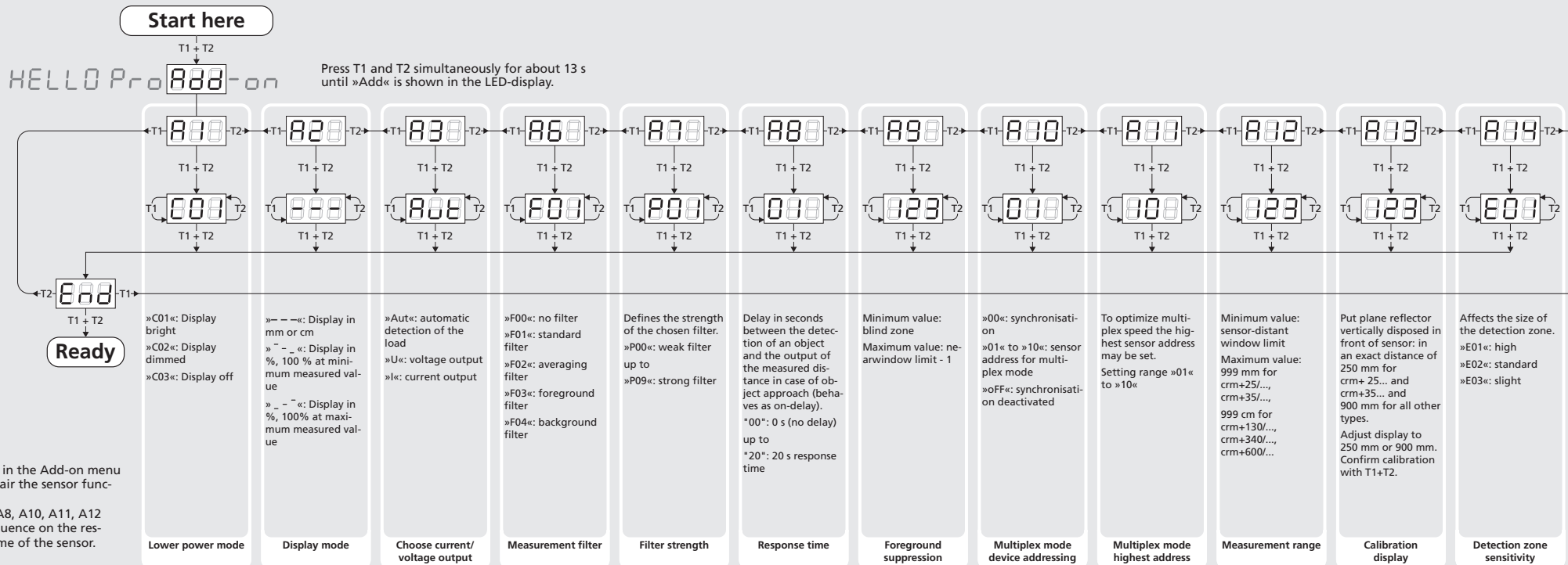
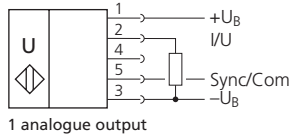

Diagram 4: Useful additional functions in Add-on menu (for experienced users only, settings not required for standard applications)



Note
Changes in the Add-on menu may impair the sensor function.
A6, A7, A8, A10, A11, A12 have influence on the response time of the sensor.

Technical data



crm+25... D•••••

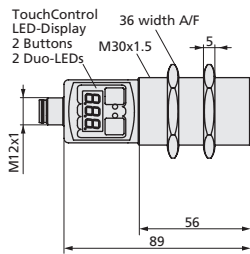

blind zone 0 to 30 mm
operating range 250 mm
maximum range 350 mm
angle of beam spread see detection zone
transducer frequency 320 kHz
resolution 0.025 to 0.10 mm, depending on the window limits

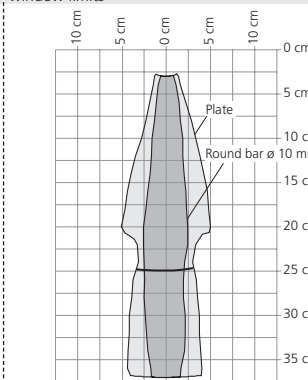

reproducibility ±0.15 %
accuracy ±1 % (Temperature drift internal compensated, may be deactivated²⁾, 0.17%/K without compensation)
operating voltage U_B 9 to 30 V DC, short-circuit-proof, Class 2
voltage ripple ±10 %
no-load supply current ≤ 80 mA
housing Stainless steel 1.4571, plastic parts: PBT, TPU; Ultrasonic transducer: PEEK film, PTFE epoxy resin with glass content

class of protection to EN 60529 IP 67
norm conformity EN 60947-5-2
type of connection 5-pin initiator plug, PBT
controls 2 push-buttons (TouchControl)
indicators 3-digit LED display, 2 three-colour LEDs with TouchControl and LinkControl
programmable with TouchControl and LinkControl
operating temperature -25 to +70 °C
storage temperature -40 to +85 °C
weight 150 g
response time¹⁾ 32 ms
time delay before availability <300 ms

order No. crm+25/IU/TC/E
current output 4 to 20 mA R_L ≤ 100 Ω at 9 V ≤ U_B ≤ 20 V
R_L ≤ 500 Ω at U_B ≥ 20 V
Rising/falling output characteristic
voltage output 0 to 10 V R_L ≥ 100 kΩ at U_B ≥ 15 V, short-circuit-proof
Rising/falling output characteristic

crm+35... D•••••

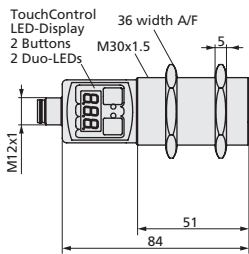

blind zone 0 bis 85 mm
operating range 350 mm
maximum range 600 mm
angle of beam spread see detection zone
transducer frequency 360 kHz
resolution 0.025 to 0.17 mm, depending on the window limits

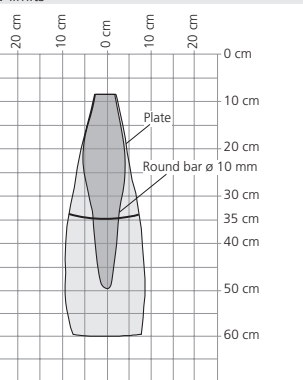

reproducibility ±0.15 %
accuracy ±1 % (Temperature drift internal compensated, may be deactivated²⁾, 0.17%/K without compensation)
operating voltage U_B 9 to 30 V DC, short-circuit-proof, Class 2
voltage ripple ±10 %
no-load supply current ≤ 80 mA
housing Stainless steel 1.4571, plastic parts: PBT, TPU; Ultrasonic transducer: PEEK film, PTFE epoxy resin with glass content

class of protection to EN 60529 IP 67
norm conformity EN 60947-5-2
type of connection 5-pin initiator plug, PBT
controls 2 push-buttons (TouchControl)
indicators 3-digit LED display, 2 three-colour LEDs with TouchControl and LinkControl
programmable with TouchControl and LinkControl
operating temperature -25 to +70 °C
storage temperature -40 to +85 °C
weight 150 g
response time¹⁾ 64 ms
time delay before availability <300 ms

order No. crm+35/IU/TC/E
current output 4 to 20 mA R_L ≤ 100 Ω at 9 V ≤ U_B ≤ 20 V
R_L ≤ 500 Ω at U_B ≥ 20 V
Rising/falling output characteristic
voltage output 0 to 10 V R_L ≥ 100 kΩ at U_B ≥ 15 V, short-circuit-proof
Rising/falling output characteristic

crm+130... D•••••

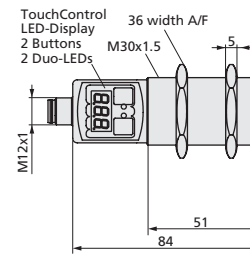

blind zone 0 to 200 mm
operating range 1,300 mm
maximum range 2,000 mm
angle of beam spread see detection zone
transducer frequency 200 kHz
resolution 0.18 to 0.57 mm, depending on the window limits

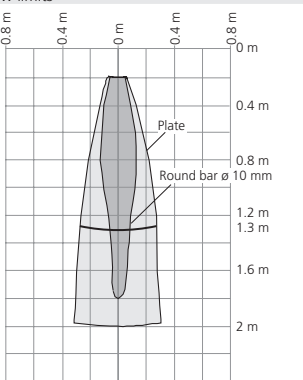

reproducibility ±0.15 %
accuracy ±1 % (Temperature drift internal compensated, may be deactivated²⁾, 0.17%/K without compensation)
operating voltage U_B 9 to 30 V DC, short-circuit-proof, Class 2
voltage ripple ±10 %
no-load supply current ≤ 80 mA
housing Stainless steel 1.4571, plastic parts: PBT, TPU; Ultrasonic transducer: PEEK film, PTFE epoxy resin with glass content

class of protection to EN 60529 IP 67
norm conformity EN 60947-5-2
type of connection 5-pin initiator plug, PBT
controls 2 push-buttons (TouchControl)
indicators 3-digit LED display, 2 three-colour LEDs with TouchControl and LinkControl
programmable with TouchControl and LinkControl
operating temperature -25 to +70 °C
storage temperature -40 to +85 °C
weight 150 g
response time¹⁾ 92 ms
time delay before availability <300 ms

order No. crm+130/IU/TC/E
current output 4 to 20 mA R_L ≤ 100 Ω at 9 V ≤ U_B ≤ 20 V
R_L ≤ 500 Ω at U_B ≥ 20 V
Rising/falling output characteristic
voltage output 0 to 10 V R_L ≥ 100 kΩ at U_B ≥ 15 V, short-circuit-proof
Rising/falling output characteristic

crm+340... D•••••

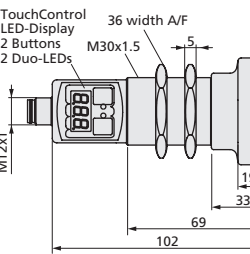

blind zone 0 to 350 mm
operating range 3,400 mm
maximum range 5,000 mm
angle of beam spread see detection zone
transducer frequency 120 kHz
resolution 0.18 to 1.5 mm, depending on the window limits

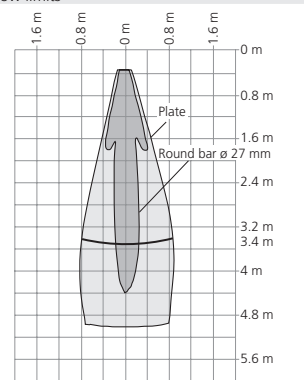

reproducibility ±0.15 %
accuracy ±1 % (Temperature drift internal compensated, may be deactivated²⁾, 0.17%/K without compensation)
operating voltage U_B 9 to 30 V DC, short-circuit-proof, Class 2
voltage ripple ±10 %
no-load supply current ≤ 80 mA
housing Stainless steel 1.4571, plastic parts: PBT, TPU; Ultrasonic transducer: PEEK film, PTFE epoxy resin with glass content

class of protection to EN 60529 IP 67
norm conformity EN 60947-5-2
type of connection 5-pin initiator plug, PBT
controls 2 push-buttons (TouchControl)
indicators 3-digit LED display, 2 three-colour LEDs with TouchControl and LinkControl
programmable with TouchControl and LinkControl
operating temperature -25 to +70 °C
storage temperature -40 to +85 °C
weight 210 g
response time¹⁾ 172 ms
time delay before availability <380 ms

order No. crm+340/IU/TC/E
current output 4 to 20 mA R_L ≤ 100 Ω at 9 V ≤ U_B ≤ 20 V
R_L ≤ 500 Ω at U_B ≥ 20 V
Rising/falling output characteristic
voltage output 0 to 10 V R_L ≥ 100 kΩ at U_B ≥ 15 V, short-circuit-proof
Rising/falling output characteristic

crm+600... D•••••

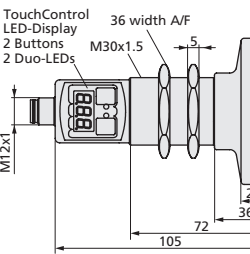

blind zone 0 to 600 mm
operating range 6,000 mm
maximum range 8,000 mm
angle of beam spread see detection zone
transducer frequency 80 kHz
resolution 0.18 to 2.4 mm, depending on the window limits

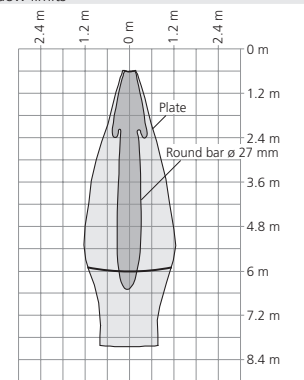

reproducibility ±0.15 %
accuracy ±1 % (Temperature drift internal compensated, may be deactivated²⁾, 0.17%/K without compensation)
operating voltage U_B 9 to 30 V DC, short-circuit-proof, Class 2
voltage ripple ±10 %
no-load supply current ≤ 80 mA
housing Stainless steel 1.4571, plastic parts: PBT, TPU; Ultrasonic transducer: PEEK film, PTFE epoxy resin with glass content

class of protection to EN 60529 IP 67
norm conformity EN 60947-5-2
type of connection 5-pin initiator plug, PBT
controls 2 push-buttons (TouchControl)
indicators 3-digit LED display, 2 three-colour LEDs with TouchControl and LinkControl
programmable with TouchControl and LinkControl
operating temperature -25 to +70 °C
storage temperature -40 to +85 °C
weight 270 g
response time¹⁾ 240 ms
time delay before availability <450 ms

order No. crm+600/IU/TC/E
current output 4 to 20 mA R_L ≤ 100 Ω at 9 V ≤ U_B ≤ 20 V
R_L ≤ 500 Ω at U_B ≥ 20 V
Rising/falling output characteristic
voltage output 0 to 10 V R_L ≥ 100 kΩ at U_B ≥ 15 V, short-circuit-proof
Rising/falling output characteristic

¹⁾ Can be programmed via TouchControl and LinkControl.
²⁾ Can be deactivated via LinkControl.